

APPLICATIONS

- RFID and GPS wake up
- Vehicle movement detection
- Motor activity monitor
- Person or animal monitor

HIGHLIGHTS

- Sensitivity control for movement detection
- Reliably detects vehicle /animal movement
- Superior performance rejecting spurious bumps / tilting
- No firmware debounce required
- Trigger tunable from 0.1 - 30 seconds of motion
- Always settles off regardless of sensor state
- Ultra low power
- Passive cost ~\$0.06 at 10K

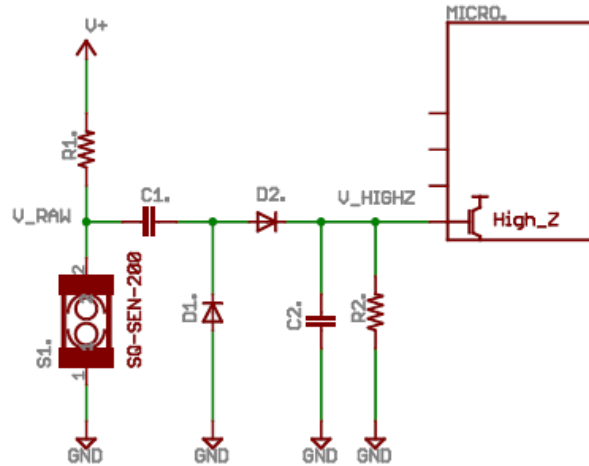

EXAMPLE OUTPUTS FROM VARIOUS SETTINGS

Example component values for each Case are provided on the following pages.

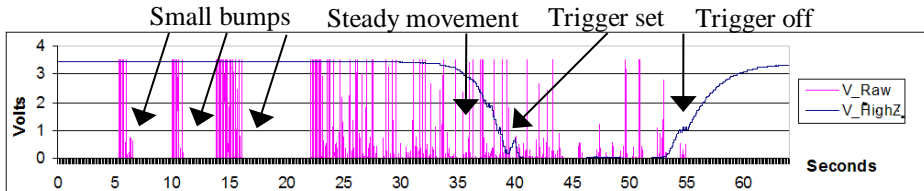
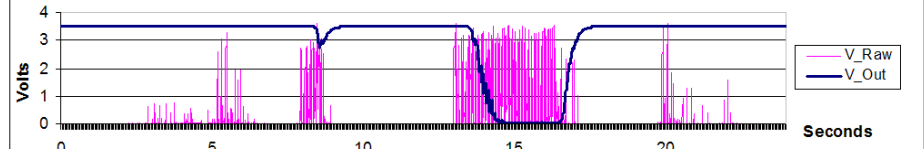
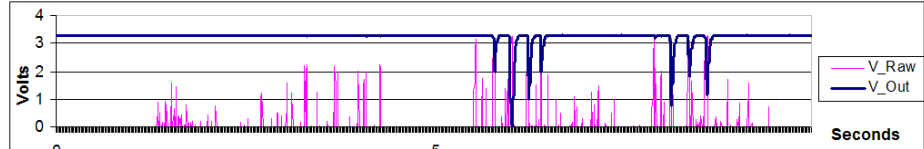
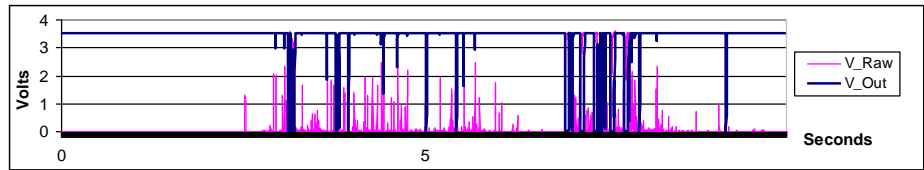
<p>CASE 1 Triggers after 3 - 15 seconds of movement. Rejects spurious bumps and tilting events. (Page 4)</p>	
<p>CASE 2 Triggers after 2 - 3 seconds movement. Rejects light vibration and bumps.</p>	
<p>CASE 3 Triggers on bumps or medium vibration. Rejects gentle tilting.</p>	
<p>CASE 4 Triggers instantly on faint motion.</p>	

THEORY OF OPERATION

COMPONENTS AND NODES

R1	Limits the continuous current drain through the sensor and hence the overall current drain of the circuit.
C1	Provides AC coupling (removes the DC state of the sensor). Low leakage capacitors can improve performance.
D1	Eliminates negative voltage spikes from creating a DC bias at the C1-D2 node. If D1 is removed, the circuit will stop responding to motion (on/off closures) after a period of time. Ultra fast diodes are recommended (not Schottky).
D2	Acts to store charge packets on C2 as the sensor opens and closes. Ultra fast diodes are recommended (not Schottky).
C2	Is the integrating capacitor. The size of C2 determines how much integration time (desensitizing) is accomplished by the circuit. Low leakage capacitors can improve performance.
R2	Leaks stored charge off of C2, thereby allowing the output of the FET to rest to a high state (open) after a certain period of time. Because the circuit is designed for ultra low current, a large value of R1 is desirable (to limit continuous current drain). Accordingly, R2 needs to be much larger than R1 so the R1-R2 ration (voltage divider) allows full swing voltage spikes to pass through D2. If R2 is too small, the voltage on C2 will not climb high enough to trigger the base gate threshold voltage of the Q1.
Q1	<p>The FET provides an ultra high impedance input for detecting the voltage accumulated on C2. A low cost N-channel FET is suitable such as the 2N7000 or 2N7002. The cost is around \$0.02 at 10K.</p> <p>With a drain-source current of 3.3 uA (1 MΩ drain resistor at 3.3 V), a typical FET gate threshold voltage for the 2N7002 is 1.5 V at extreme low temperature and 0.6 V at extreme high temperature. Higher drain-source currents (i.e. smaller drain resistors) will increase the gate threshold voltage. At 25 C with a 30 uA load, a typical gate threshold voltage is about 1.7 V.</p>
R3	Using a higher value of R3 will lower the gate threshold voltage by reducing the drain-source current of the FET. This is recommended for low voltage, low current applications. However, the off-to-on transition output of the FET will be somewhat less clean when using a larger value of R3.
MICRO	If interfacing to a microcontroller, the impedance of its input pin needs to be very high. Pull ups should be disabled. If the input impedance is not high enough to achieve a high Z/R1 ratio, then pin can be driven with V_Out from the FET (seen in example).

BUFFERING & TESTING

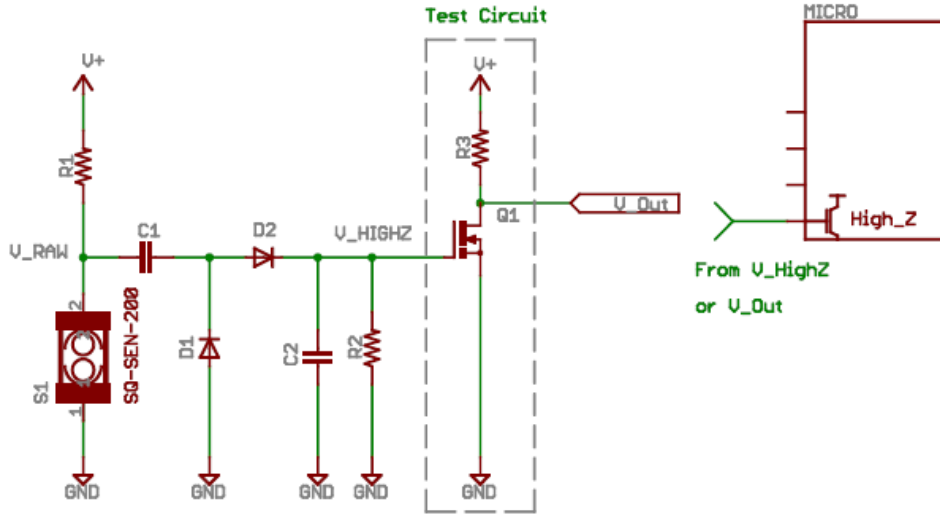

BEHAVIOR

At rest, Q1 will have a guaranteed high (open) output and will produce a low going signal when motion is detected. A key feature of this circuit is that it will always settle in a know state (open) when at rest, which avoids a potential current leak if the sensor “hovers” between open and closed. If a normally low output is desired, then R3 can be moved to the emitter side of the FET.

NOTES

The Test Circuit above should be use to verify correct functionality and sensitivity. By measuring V_Out with an oscilloscope, an intuitive understanding of the circuit’s behavior can be gained.

Measuring V_HighZ with a standard oscilloscope or voltage meter **WILL DRAMATICALLY ALTER** the behavior of the circuit. Typical oscilloscopes have input impedance from 1M to 10M and this will load the high impedance node causing severe voltage droop. This is why the Test Circuit shown above is recommend for prototyping.

In many applications, connecting the output of the FET (V_Out) to the host microcontroller’s input pin provides improved performance when compared to using V_HighZ.

NON-MICROCONTROLLER APPLICATIONS

Applications that do not make use of a microcontroller can also be constructed from the above circuit. By replacing R3 with a LED, buzzer or other load, a simple movement detection indicator can be constructed. Depending on the choice of the Q1 FET, higher loads can be driven (i.e. connecting power direly to a GPS receive unit, turning on a motor etc.).

CASE 1

Triggers after 3 - 15 seconds of movement. Rejects spurious bumps and tilting events.

DETAILED DESCRIPTION

You want to produce a “wake up” signal if an object is moving, but not if it is bumped or tilted. In your application, it is acceptable if the signal is generated 3 – 5 seconds after heavy vibration begins, or 10 – 15 seconds after gentle movement begins.

VALUES

- V_{cc} = 3.3 V
- R1 = 2.5 MΩ
- C1 = 0.01 uF
- D1 and D2 = ultra fast diode (not Schottky)
- C2 = 1 uF
- R2 = 40 MΩ (4x 10 MΩ in series)
- R3 = 1 MΩ
- Average current is about 1.3 uA at rest

TUNING

If the response time is not fast enough, the C2 value can be lowered. To achieve a good balance between noise rejection and response time try 0.47 uF first and then 0.22 uF.

The value for C1 is not critical. Values from 0.01 uF to 0.1 uF are suitable. Likewise, the value for C2 is not critical. Values of 0.1 uF to 1.0 uF are suitable.

USING SUPPLY VOLTAGES BELOW 3.3V

Slightly higher sensitivity can be achieved at low voltage using a C1 value closer to 1 uF.

At lower voltages, the sensitivity of the circuit will decrease. Lowering R1 to 2 MΩ or even 1 MΩ will dramatically increase sensitivity.

CONDITIONS: V_{CC} = 3.3V

TABLE OF VALUES

	R1	C1	C2	R2	R3	Trigger sensitivity
CASE 1	2.5 MΩ	0.01 uF	1 uF	40 MΩ	2.5 MΩ	3 – 15 sec of movement
CASE 2	2.5 MΩ	0.1 uF	1 uF	30 MΩ	2.5 MΩ	2 – 5 sec of movement
CASE 3	2.5 MΩ	0.01 uF	0.1 uF	30 MΩ	2.5 MΩ	Small and mid sized bumps
CASE 4	2.5 MΩ	0.01 uF	0.001 uF	30 MΩ	2.5 MΩ	Faint motion